

TITLE:

COWHORN BRACKET

PART NO:

-

DRAWING NUMBER:

910004720-1

SIZE:

A3

ISSUE:

A

REV. RECORD

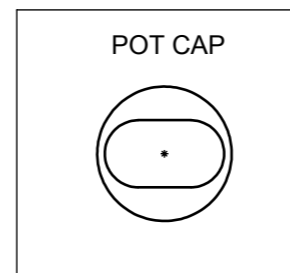
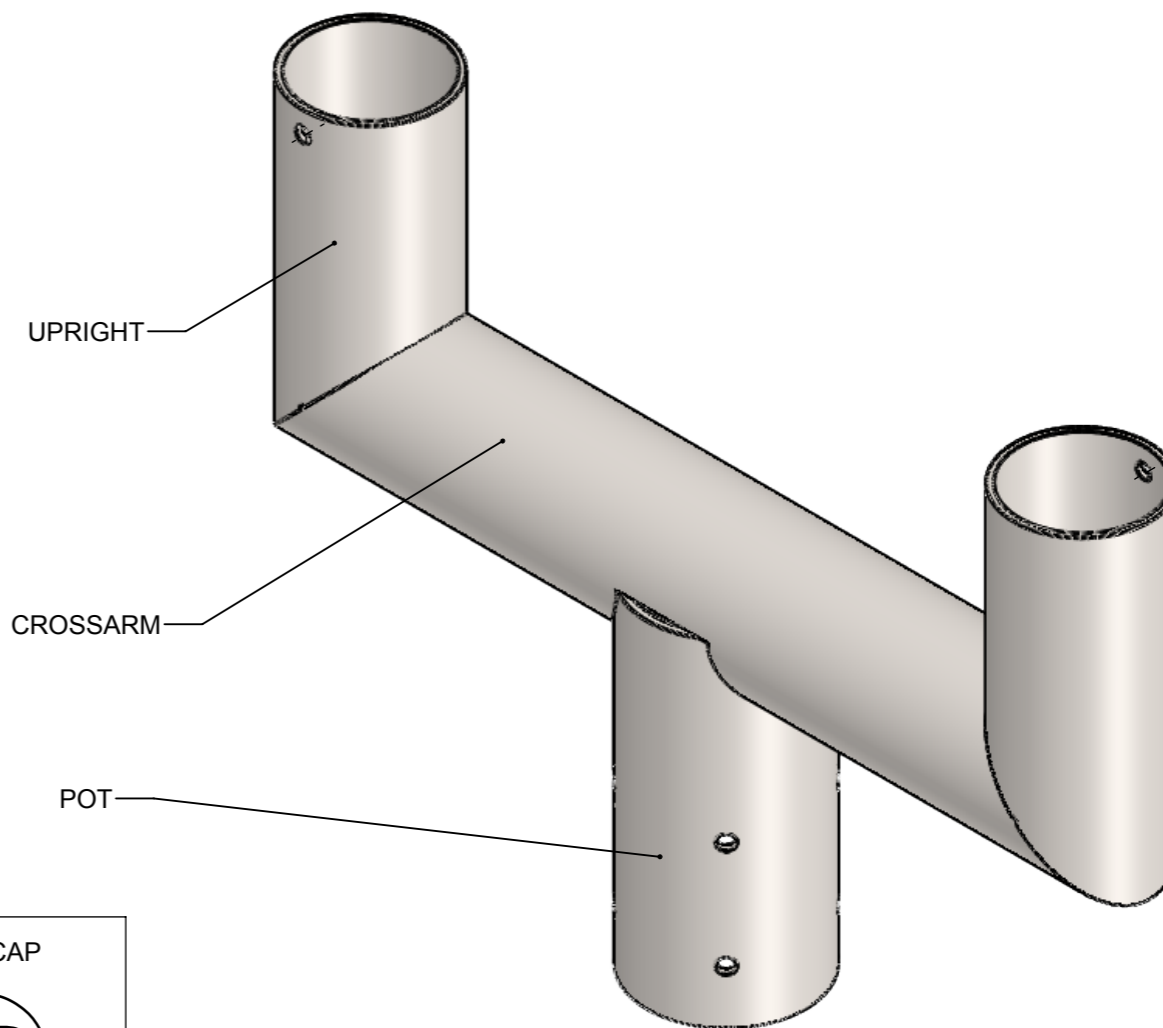
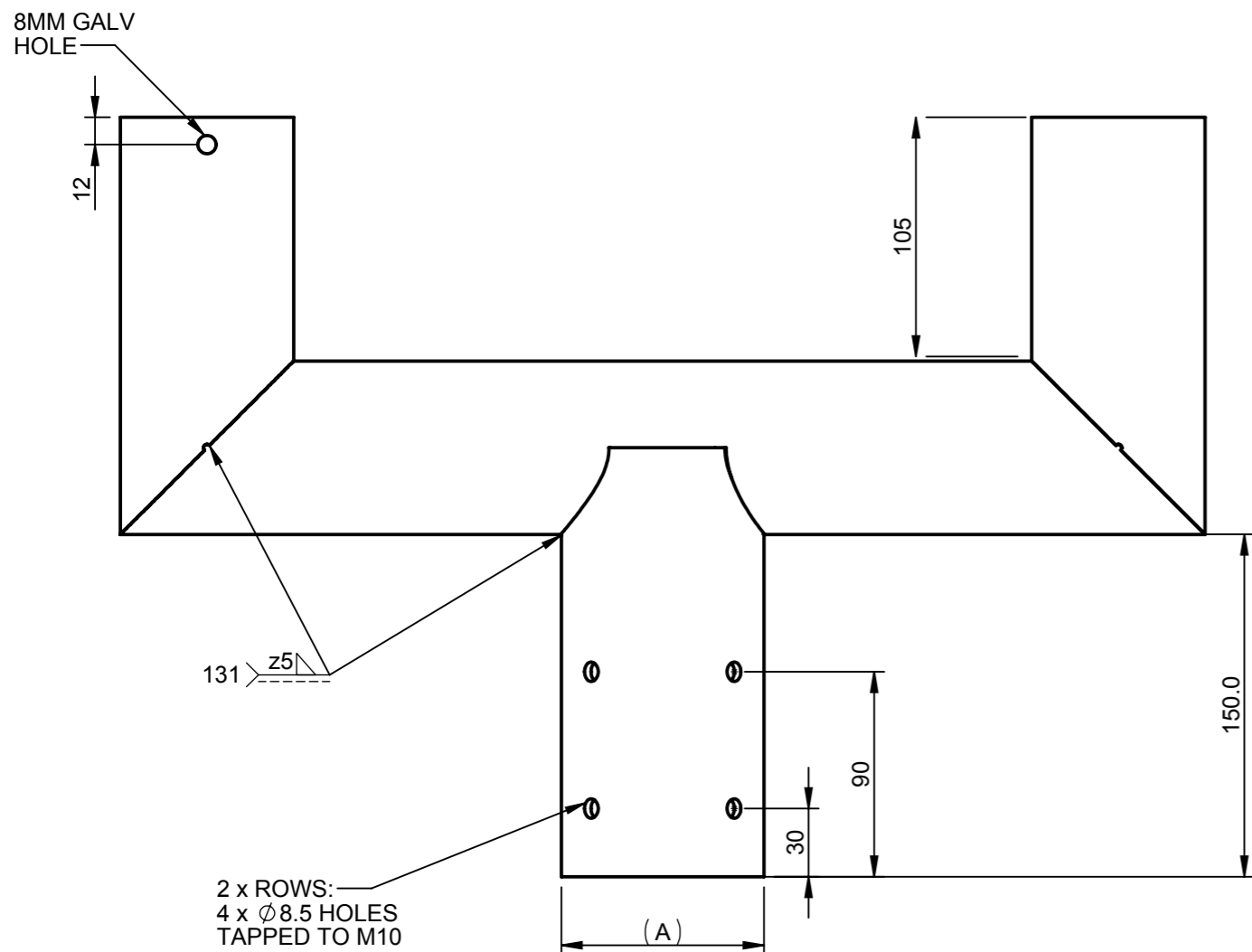
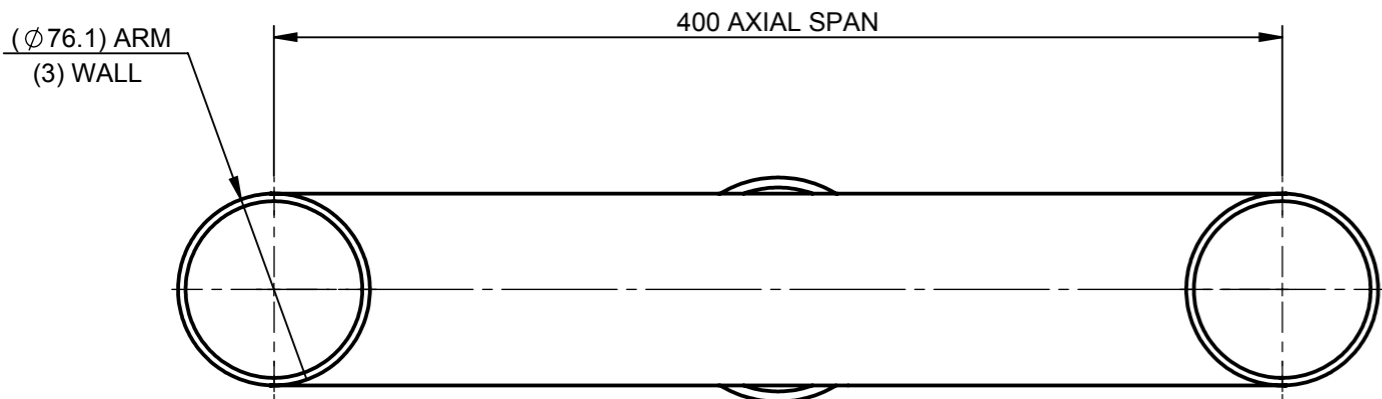

PART NO:	POT DIA (A)	CAP USED
910004720	88.9	N
910004721	101.6	Y
910004722	114.3	Y
910004723	127.0	Y
910004724	152.4	Y
910004725	168.3	Y

NOTE(S):
(1) POT CAP USED ON MAJORITY OF BRACKETS. SEE TABLE

NOTES: (1) ALL DIMENSIONS IN mm. (2) REMOVE ALL BURRS AND SHARP EDGES.

© 2017 PUDSEY DIAMOND ENGINEERING LTD. ALL RIGHTS RESERVED. THIS DOCUMENT OR ANY PART THEREOF MAY NOT BE REPRODUCED, STORED IN A RETRIEVAL SYSTEM OR TRANSMITTED IN ANY WAY WITHOUT WRITTEN PERMISSION FROM PUDSEY DIAMOND ENGINEERING LTD.

<p>LINEAR TOLERANCES UNLESS OTHERWISE STATED: X.00 = \pm0.15 X.0 = \pm0.50 X = \pm5.00</p>	<p>ANGULAR TOLERANCES UNLESS OTHERWISE STATED: X.00° = \pm0.15° X.0° = \pm0.50° X° = \pm1.00°</p>	<p>MATERIAL: MILD STEEL</p> <p>SPEC: S275</p>	
<p>DATE: 11/04/2017</p>	<p>SCALE: NTS</p>	<p>FINISH: GALVANISED</p>	
<p>DRAWN: EMM</p>	<p>CHECKED: IG</p>	3RD ANGLE PROJECTION	